

ParkOne 2

Udviklet af Needit Denmark
Designet af John Sebastian

Brugervejledning

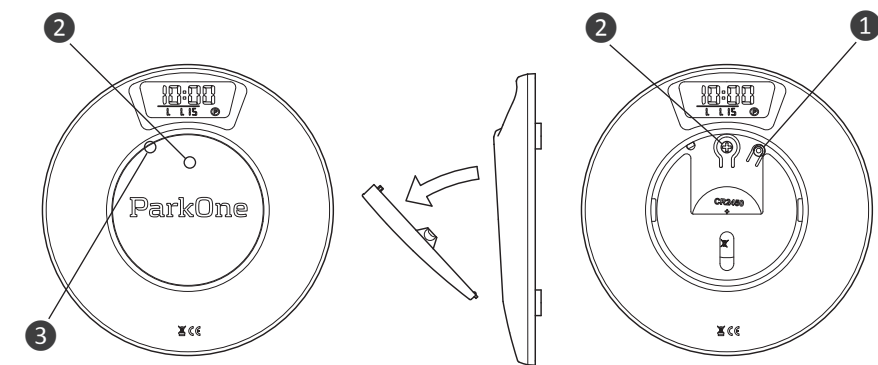

www.parkone.dk

Inden montering

Vend P-skiven med bagsiden opad. Sæt en eller flere negle ind i sprækken øverst på den runde bagklap og træk låget af.

A: Aktiver batteriet

Fjern forsigtigt plaststrimlen, og pres batteriet på plads igen, hvis det løsner sig. Skulle batteriet falde ud, indsættes det igen med + opad (samme side som den med tekst). Er batteriet korrekt placeret, blinker ”timer” i displayet. (Der kan gå lidt tid, før tallet i displayet blinker).

B: Indstil det digitale ur

(Uret i ParkOne 2 indstiller selv både sommer- og vintertid, men funktionen kan om nødvendigt deaktiveres manuelt, se C:)

1. Aktiver indstillingstilstand ved at trykke med en spids genstand på knap ❶ og hold knappen inde til ”timer” begynder at blinke.
2. Når ”timer” blinker, skal du trykke gentagne gange på knap ❷, indtil timetallet er korrekt indstillet.
3. Tryk én gang på knap ❶, og ”minutter” blinker. Indstil minutter med knap ❷.
4. Indstil år, måned og dato som ovenfor (i nævnte rækkefølge).

Når du har indstillet ovenstående oplysninger, må ingen tal i displayet blinke.

Bemærk dog, at de to prikker (:) imellem klokkeslættet blinker hele tiden. Hvis ét af tallene blinker, tryk da gentagne gange på knap ❶ indtil ingen af tallene blinker.

Hvis du opdager, at du har indstillet ParkOne 2 forkert, kan du altid begynde forfra på indstillingerne ved at holde knap ❶ inde til tallet ”timer” blinker.

Det anbefales at kontrollere urets indstillinger jævnligt, især ved skift mellem sommer- og vintertid.

1

C: Aktivering/deaktivering af sommertid/vintertid.

Det digitale ur er som standard indstillet til selv at skifte mellem sommer- og vintertid. Men hvis du befinder dig i et land, hvor der ikke skiftes, kan du deaktivere funktionen ved at følge nedenstående trin:

1. Aktiver indstillingstilstand ved at trykke på både knap ❶ og ❷, indtil ”timer” og ”minutter” viser ”oN:Su”.
2. Slip langsomt knap ❶.
3. Hold knap ❷ inde til displayet viser ”oF:Su”.
4. Displayet vender automatisk tilbage til funktionstilstand.

Din ParkOne 2 er nu klar til montering indvendigt på bilens forrude.

Husk, at det kun er tilladt at have én P-skive i bilen, og at det altid er førerens ansvar, at uret er stillet korrekt.

Needit ApS og Needit Denmark ApS refunderer ikke P-afgifter.

Montering af ParkOne 2

Find det bedste sted indvendigt på forrudens nederste højre hjørne (lovkrav), hvor alle fire klæbepuder berører ruden. Sørg for, at du har adgang til alle knapperne på bagsiden af uret, og at du kan komme til at skifte batteriet.

1. Gør ruden ren indvendigt med en fugtig klud med en smule opvaskemiddel, hvor P-skiven skal monteres. Tør ruden, og brug derefter den medfølgende renseserviet til at rense området grundigt. (Kun den medfølgende serviet må bruges – ikke andre rensedmidler.)

2

2. Sørg for, at ruden er mindst +15°C, da klæbepuderne ikke fungerer tilfredsstillende ved lavere temperaturer. Varm eventuelt ruden op med bilens blæser eller (med forsigtighed) en hårtørrer.
3. Fjern beskyttelsesfolien fra de fire klæbepuder, og pres P-skiven hårdt ind mod ruden i ca. 30 sekunder. Undgå at presse på bagsidens midte. Kontroller derefter udefra, at alle fire puder klæber ordentligt til ruden.
4. Du har nu monteret din ParkOne 2 og er klar til at køre.

NB!

ParkOne 2 må ikke ligge løst i bilen, men skal være fastmonteret på ruden for at fungere korrekt.

Sådan fungerer ParkOne 2

Det er førerens ansvar at sørge for, at uret er indstillet korrekt. P-afgifter afholdes ikke af Needit ApS og Needit Denmark ApS, ligesom monteringsfejl ikke er Needits ansvar.

Når du parkerer bilen, stiller ParkOne 2 sig automatisk frem til nærmeste kvarter efter ankomsttidspunktet (f.eks. ved ankomst 10:07 stiller ParkOne 2 sig på 10:15).

Manuel indstilling

Som loven kræver det, kan din ParkOne 2 også stilles manuelt. BEK. nr. 327 af 9/04/2003 (§3 stk. 3): ”Såfremt der under et køretøjs parkering indtræder en periode uden tidsbegrænsning, skal viseren senest ved periodens udløb indstilles på det tidspunkt, hvorfra der på ny gælder en tidsbegrænsning.” Hvis du har behov for at stille din ParkOne 2 manuelt, skal du blot trykke på knap ❷, og uret tæller frem i intervaller på 15 minutter. Hold knappen inde, og slip, når det ønskede tidspunkt vises. Bemærk, at denne funktion kun er tilgængelig, når ParkOne 2 er i parkeringstilstand.

3

Godkendelser og certifikater

ParkOne 2 er godkendt af Trafikstyrelsen med henvisning til Bekendtgørelse nr. 327 af 9/04/2003 om parkeringskiver og bærer styrelsens godkendelsesnummer FS26 på forsiden.

CE-mærkning

Med CE-mærket erklærer Needit ApS, at vores produkt opfylder de generelle sikkerhedskrav i relevante CE-mærkningsdirektiver. Med CE-mærket garanterer producenten, at produktet er fremstillet i overensstemmelse med fælleseuropæiske krav til sikkerhed, sundhed og miljø. Needit ApS erklærer hermed, at denne parkeringsskive er i overensstemmelse med (CE) EN 55022 (Radio Disturbance Characteristics) og (CE) EN 55024 (Standards for Commercial Electronic Products).

WEEE

Elektriske og elektroniske komponenter (EEE) og materialer kan være farlige og skadelige for helbred og miljø og skal bortskaffes korrekt. ParkOne 2 må ikke bortskaffes sammen med almindeligt husholdningsaffald, men skal indsamles særskilt. Batteriet kan afleveres hos forhandlere af batterier, og selve ParkOne 2 kan afleveres på den lokale genbrugsstation eller der, hvor P-skiven er købt.



5

Specifikationer og rettigheder

Størrelse i cm: 10 x 10 x 1,5

Batterispecifikation: Knapbatteri nr. CR 2450 - 3 Volt

Batteriets levetid: Ca. 2 år

Urets nøjagtighed (gns.): ± 2 min./2 år

Reaktionstid – parkeringstilstand: Ca. 20 sek.

Reaktionstid – ud af parkeringstilstand: Ca. 20 sek.

ParkOne 2 er patentanmeldt.

Alle rettigheder til produktet ParkOne 2 tilhører:

Needit ApS • Hammerholmen 18 • 2650 Hvidovre

Telefon: +45 70 221 535

E-mail: kundeservice@needit.dk

Website: www.needit.dk

Der tages forbehold for, at indholdet af denne brugervejledning kan ændres.

VIGTIGT

Det er førerens ansvar at sørge for, at uret er indstillet korrekt. P-afgifter afholdes ikke af Needit ApS og Needit Denmark ApS, ligesom monteringsfejl ikke er Needit ApS' ansvar.

4

DA, EN v. 001 6

ParkOne 2

Developed by Needit Denmark
Designed by John Sebastian

Instructions for use

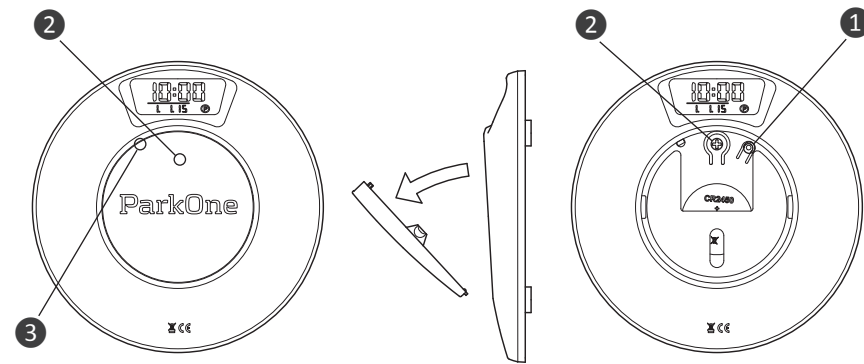

Before fitting

With the back of the parking disk facing you, slide one or two nails into the slit at the top of the circular back cover and pull it off.

A: How to activate the battery:

Carefully remove the plastic strip. Press the battery back into place if it has become dislodged. If the battery falls out, replace it with + facing upwards (same side as text). If the battery is inserted correctly, "hours" flashes in the display. (There may be a slight delay before the display starts to flash).

B: How to set the digital clock:

(The ParkOne 2 parking disc clock sets automatically even when the clocks go back or forward (daylight saving time). However, if necessary, this function can be deactivated manually (see C below).

1. To activate the setting function, press and hold down button ❶ with a sharp point until "hours" starts to flash.
2. When "hours" flashes, press repeatedly on button ❷ until the clock is set at the correct hour.
3. Press button ❶ once until "minutes" starts to flash. Set minutes using button ❷.
4. Set year, month and date as described above (in this order).

When the above settings is completed, none of the digits in the display should flash.

NB: Note, however, that the two dots (:) between the hours and minutes flash all the time. If one of the digits flashes, press button ❶ repeatedly until no digits are flashing. If you discover that you have set ParkOne 2 incorrectly, you can always start again. Press and hold down button ❶ until the "hours" digit flashes.

We recommend that you check the parking disc settings regularly, especially after the clocks go back/forward.

1

C: Activating/deactivating daylight saving time

By default the digital clock is set to change automatically to and from daylight saving time. If, however, you are in a country which does not use daylight saving time, you can deactivate this mode as follows:

1. To activate the setting function, press buttons ❶ and ❷ until "hours" and "minutes" show "oN:Su" in the display.
2. Carefully release button ❶.
3. Press and hold down button ❷ until you read "oF:Su" in the display.
4. The display reverts automatically to normal mode.

Your ParkOne 2 is now ready for fitting on the inside of your car windscreen.

Don't forget: you are permitted to have only one parking disk in the vehicle. The driver is always responsible for setting the clock correctly.

Needit ApS and Needit Denmark ApS do not refund parking fines.

How to fit ParkOne 2

Find a suitable spot inside the car at the lower, right-hand corner of the windscreen (this is a legal requirement) where all four adhesive pads are in contact with the glass. Make sure that you are able to access all the buttons on the back of the parking disc and that you are able to change the battery.

1. Clean the area on the inside of the windscreen where you will be fixing your parking disc with a damp cloth and a little household detergent. Dry the windscreen and then use the enclosed cleaning cloth to thoroughly degrease the area. (Use the enclosed cleaning cloth – no other cleaning agents).

2

2. Make sure that the windscreen is at least +15°C. The adhesive pads are not as effective at lower temperatures. The glass can be heated using the car heater or (carefully) with a hair dryer.
3. Remove the protective foil from the four adhesive pads and press the parking disc hard against the glass for about 30 seconds. Do not press on the middle of the back of the disc. Check from the outside that all four adhesive pads have adhered to the glass.
4. You have now fitted your ParkOne 2 parking disc and are ready to drive.

NOTE! ParkOne 2 parking disc must not be left unattached in the car. Your parking disc will not function correctly unless it is permanently attached to the windscreen.

How does ParkOne 2 work?

The driver of the vehicle is responsible for ensuring that the disc is set correctly. Needit ApS and Needit Denmark do not pay parking fines and Needit cannot accept responsibility for defective fitting. When you park your car, ParkOne 2 sets automatically to the next quarter of an hour after your time of arrival (e.g. if you arrive at 10:07, ParkOne 2 sets itself to 10:15).

How to set arrival time manually

Your ParkOne 2 can also be set manually. This function is a legal requirement in Denmark. Executive Order no. 327 of 9/04/2003 (Article 3(3)) states: "If, while the vehicle is parked, a period begins in which unlimited parking is permitted, the parking disc must be set (no later than the end of this period) to display the time from which a new limited parking period will begin." If you need to set your ParkOne 2 parking disc manually, press button ❷ and the clock will run on at 15-minute intervals. Press and hold down the button. Release the button when you reach the required time. NB: This function is only accessible when ParkOne 2 parking disc is in parking mode.

3

Approvals and certificates

ParkOne 2 is approved by the Danish Transport Authority in accordance with Executive Order no. 327 of 9/04/2003 on parking discs and approval code FS26 is imprinted on the front.

CE labelling

By means of the CE label on the parking disc, Needit ApS declares that our product meets the general safety requirements contained in the CE labelling directives. By means of the CE label, the manufacturer guarantees that the product is manufactured in accordance with joint European safety, health and environmental requirements. Needit ApS declares that this parking disc meets (CE) EN 55022 (Radio Disturbance Characteristics) and (CE) EN 55024 (Standards for Commercial Electronic Products) requirements.

WEEE

Electrical and electronic components (EEE) and materials can be harmful to the health and environment, and must be correctly disposed of.

ParkOne 2 is not to be disposed of in the general trash, but has to be disposed of individually. The battery can be returned at any retailer selling batteries, and the actual ParkOne 2 can be disposed of at your local recycling station or at the retailer.



5

Battery

If the red diode ❸ flashes for a period of 10 seconds each time ParkOne 2 enters or leaves parking mode, the battery must be replaced within a week. A suitable battery can be purchased at any store selling button cell batteries.

DON'T FORGET TO RESET THE PARKING DISC CLOCK.

When the battery is replaced, the parking disc clock resets automatically. You can reset any settings as described above. NB: Note that the LCD display in your ParkOne 2 parking disc disappears shortly after the battery has been removed. You should therefore avoid leaving the car while there is no battery in the parking disc.

How to replace the battery

1. Buy a button cell battery CR 2450 - 3 Volt.
2. Pull off back cover.
3. Insert a sharp point into the rectangular hole beneath the battery and push it up.
4. Insert new battery. Don't forget to wipe the battery with a cloth before inserting.
5. Replace the back cover.

Service and guarantee

If you have questions about your new ParkOne 2, you will find many answers on our website at www.needit.dk. If you have questions, you are also welcome to send an e-mail to kundeservice@needit.dk. Needit ApS and Needit Denmark ApS provide a product guarantee in accordance with the Danish Sale of Goods Act. If, during the guarantee period, you find an error or defect in your ParkOne 2 parking disc, you can return it to the retailer, from whom you bought the disc. The disc will be repaired or replaced. If you have a complaint, please bring a copy of your receipt (as proof of purchase).

4

Specifications and rights

Size (cm): 10 x 10 x 1.5

Battery specification: Button cell battery CR 2450 - 3 Volt

Battery lifetime: About 2 years

Clock precision (avg.): ± 2 min./2 years

Response time – parking: About 20 seconds

Response time – not in parking function: About 20 seconds

ParkOne 2 patent applied for.

All rights to the ParkOne 2 product are the property of:

Needit ApS • Hammerholmen 18 • DK-2650 Hvidovre

Telephone: +45 70 221 535

E-mail: kundeservice@needit.dk

Website: www.needit.dk

We reserve the right to make changes to the content of these instructions without prior warning.

NOTE:

The driver of the vehicle is responsible for ensuring that the disc is set correctly. Needit ApS and Needit Denmark do not pay parking fines and Needit cannot accept responsibility for defective fitting.

6